

Classification: OFFICIAL
Choose address from drop down
Tel: 01895 837200 | Fax: 01895 832750
www.chiltern.gov.uk | www.southbucks.gov.uk



Stronger in partnership

The Directors

Tesco Stores Limited

Tesco House
Shire Park, Kestrel Way
Welwyn Garden City
AL7 1GA

Olu Sokoya
Senior Environmental Protection Officer

01895837361
olu.sokoya@southbucks.gov.uk

6th June 2018

EP Permit ref H418/1/74/P1364
Variation ref H418/1/74/P1364/18/VAR

Variation Notice

Chiltern & South Bucks District Councils

**The Environmental Permitting (England & Wales) Regulations 2016, Regulation 20
PG 1/14 (13) – UNLOADING OF PETROL INTO STORAGE AND MOTOR VEHICLE REFUELLING
LOCATION: TESCO AMERSHAM 3917, LONDON ROAD, LONDON ROAD WEST, AMERSHAM
BUCKINGHAMSHIRE HP7 0HA**

To: Tesco Stores Limited, (**Company No: 00519500**),

Chiltern & South Bucks District Councils ("the Council"), in the exercise of the powers conferred upon it by regulation 20 of the Environmental Permitting (England and Wales) Regulations 2016¹ ("the 2016 Regulations") hereby gives you notice as follows-

The Council has decided to vary the conditions of permit reference H418/1/74/P1364 granted under regulation 13(1) of the 2016 Regulations in respect of the operation of the installation at **Tesco Amersham 3917, London Road West, Amersham HP07 0HA**. This is required periodically i.e. every 6-8years to ensure permits are up to date and conditions fit for purpose.

The variation of the conditions of the permit and the date on which they are to take effect are specified in Schedule 1 to this notice. There is no fee applicable for this variation.

Signed on behalf of Chiltern & South Bucks Councils.

Date 6.6.18

Environmental Health Manager

An authorised officer of the Council

Classification: OFFICIAL
Choose address from drop down
Tel: 01895 837200 | Fax: 01895 832750
www.chiltern.gov.uk | www.southbucks.gov.uk



Stronger in partnership

EP Permit ref H418/1/74/P1364
Variation ref H418/1/74/P1364/18/VAR

Schedule 1 (Example)

Variation to the conditions of the permit	Date(s) on which the variation is to take place
Permit varied to bring it up to date and ensure conditions are fit-for-purpose as outlined in PG 1/14 (13)	Friday, 8 th June 2018
Revised Conditions 1 – 37 of H418/1/74/P1364 now replaced with Conditions 1 – 17 of H418/1/74/P1364/18/VAR to include appendices 1 – 3.	Friday, 8 th June 2018

Signed on behalf of Chiltern & South Bucks District Councils

Date 6.6.18

Environmental Health Manager
An authorised officer of the Council

EP Permit ref H418/1/74/P1364
Variation ref H418/1/74/P1364/18/VAR

Guidance for operators receiving a Variation Notice

(This guidance does not form part of the Variation Notice, but it is for the guidance of those served with the notice.) Further guidance can be found in the PPC [General Guidance Manual](#).

Dealing with a Variation Notice

This notice varies the terms of the permit specified in the Notice by amending or deleting certain existing conditions and/or adding new conditions. The Schedules attached to the notice explain which conditions have been amended, added or deleted and the dates on which these have effect.

The Council may have included a 'consolidated permit', which takes into account these and previous variations. Where a consolidated permit is not included this variation notice must be read in conjunction with your permit document.

Offences

Failure to comply with a Variation Notice is an offence under regulation 38(2) of the 2010 Regulations. A person guilty of an offence under this regulation could be liable to (i) a fine of up to £50,000 or imprisonment for a term not exceeding 6 months or both; or (ii) to an unlimited fine or imprisonment for a term not exceeding 5 years or both, depending on whether the matter is dealt with in the Magistrates or Crown Court.

Appeals

Under regulation 31 and Schedule 6 of the 2010 Regulations operators have the right of appeal against the conditions attached to their permit by a variation notice. The right to appeal does not apply in circumstances where the notice implements a direction of the Secretary of State/Welsh Ministers given under regulations 61 or 62 or a direction when determining an appeal.

Appeals against a Variation Notice do not have the effect of suspending the operation of the Notice. Appeals do not have the effect of suspending permit conditions, or any of the mentioned notices.

Notice of appeal against a Variation Notice must be given within **two months** of the date of the variation notification, which is the subject matter or the appeal. The Secretary of State/Welsh Ministers may in a particular case allow notice of appeal to be given after the expiry of this period, but would only do so in the most compelling circumstances.

How to appeal

There are no forms or charges for appealing. However, for an appeal to be valid, appellants (the person/operator making the appeal) are legally required to provide the Secretary of State or Welsh Minister with the following (see paragraphs 2(1) and (2) of Schedule 6 of the 2010 Regulations):

- written notice of the appeal
- a statement of the grounds of appeal;
- a copy of any relevant application;
- a copy of any relevant environmental permit;
- a copy of any relevant correspondence between the appellant and the regulator;
- a copy of any decision or notice which is the subject matter of the appeal; and
- a statement indicating whether the appellant wishes the appeal to be in the form of a hearing or dealt with by way of written representations.

Appellants should state whether any of the information enclosed with the appeal has been the subject of a successful application for confidentiality under regulation 48 of the 2010 Regulations, and provide relevant details – see below. Unless such information is provided all documents submitted will be open to inspection.

Where to send your appeal documents

Appeals should be despatched on the day they are dated, and addressed to:

The Planning Inspectorate
Environment Team, Major and Specialist Casework
Room 4/04 Kite Wing
Temple Quay House
2 The Square
Temple Quay
Bristol BS1 6PN

Or for appeals in Wales:

The Planning Inspectorate
Crown Buildings
Cathays Park
CARDIFF
CF10 3NQ

If an appeal is made, the main parties will be kept informed about the next steps, and will also normally be provided with additional copies of each other's representations.

To withdraw an appeal – which may be done at any time - the appellant must notify the Planning Inspectorate in writing and copy the notification to the local authority who must in turn notify anyone with an interest in the appeal.

Costs

The operator and local authority will normally be expected to pay their own expenses during an appeal. Where a hearing or inquiry is held as part of the appeal process, by virtue of paragraph 5(6) of Schedule 6, either the appellant or the authority can apply for costs. Applications for costs are normally heard towards the end of the proceedings and will only be allowed if the party claiming them can show that the other side behaved unreasonably and put them to unnecessary expense. There is no provision for costs to be awarded where appeals are dealt with by written representatives.

Classification: OFFICIALClassification: OFFICIAL
Choose address from drop down
Tel: 01895 837200 | Fax: 01895 832750
www.chiltern.gov.uk | www.southbucks.gov.uk



Stronger in partnership

Confidentiality

An operator may request certain information to remain confidential, i.e. not be placed on the public register. The operator must request the exclusion from the public register of confidential information at the time of supply of the information requested by this notice or any other notice. The operator should provide clear justification for each item wishing to be kept from the register. The onus is on the operator to provide a clear justification for each item to be kept from the register. It will not simply be sufficient to say that the process is a trade secret.



CHILTERN
District Council

SOUTH BUCKS
District Council

H418/1/74/P1364/18/VAR

Local Air Pollution Prevention and Control, LAPPC



PERMIT (PART B) – STAGE I & II

PART B PROCESS – UNLOADING OF PETROL INTO STORAGE, AND MOTOR VEHICLE REFUELLING, AT SERVICE STATIONS (DECEMBER 2013)

Previous Permit Ref: H418/1/74/P1364

New Permit Ref: H418/1/74/P1364/18/VAR

PG 1/14/13 (13) (Dec 2013)

Issued by:

CHILTERN & SOUTH BUCKS DISTRICT COUNCIL

Incorporating the updated 4 Yearly Review for LAPPC (February 2018)

Pollution Prevention and Control Act 1999

Pollution Prevention and Control (England & Wales) Regulations 2000,

Part 2 of schedule 3 of the PPC Regulations, SI 2000/1973

Environmental Permitting (England & Wales) Regulations 2016

CLAIRE
Chiltern's Local AIR & Environment

Original application received – 21st May 1998, Permit varied 28th October 2009, Permit varied 2nd March 2018

Classification: OFFICIALClassification: OFFICIAL

Choose address from drop down

Tel: 01895 837200 | Fax: 01895 832750

www.chiltern.gov.uk | www.southbucks.gov.uk



CHILTERN
District Council



SOUTH BUCKS
District Council

Stronger in partnership

Permit Reference Number: H418/1/74/P1364/18/VAR

Name and Address of the Operator:

Tesco Stores Limited, Tesco House, Shire Park, Kestrel Way, Welwyn Garden City, AL7 1GA

Registered Number and Office of a Company:

Tesco Stores Limited, Tesco House, Shire Park, Kestrel Way, Welwyn Garden City, AL7 1GA

Address of permitted installation:

Tesco Amersham 3917, London Road West, Amersham, Buckinghamshire HP7 0AH

The installation boundary and key items of equipment mentioned in permit conditions are shown in plans attached to this permit.

Activity description

The purpose of the description is to set down the main characteristics of the activity, including any directly associated activities, so it is clear to all concerned what is being authorised and therefore what changes would need further approval. Authorities are advised to include a description of any key items of arrestment and monitoring equipment the operator intends to use or is using. E.G:- The unloading of petrol into stationary storage tanks at a service station.

The stationary technical unit comprises the following: - 4 X Storage Tanks: - Tank 1, Volume 22.53m³, Tank 2, Volume 45.06m³, Tank 4 Volume 45.24m³ and Tank 5, Volume 45.19m³. Delivery and vapour return hoses, Vapour recovery system, and Tank vapour release point all as described in the site plan

Conditions:

Petrol Delivery

1. Vapours displaced by the delivery of petrol into storage tanks shall be returned through a vapour-tight connection line to either the mobile container delivering the petrol or a container on the site.
2. Petrol delivery shall only be carried out using the Stage II petrol vapour recovery system and deliveries shall only be made when the system is fully operational.

Motor Vehicle Refuelling

3. Motor vehicle refuelling with petrol shall only take place when the Stage II petrol vapour recovery system is fully operational and operating in accordance with the requirements of Condition 4.
4. The petrol vapour capture efficiency of the Stage II petrol vapour recovery system shall be equal to or greater than 85% but less than 115% as certified by the manufacturer in accordance with relevant European technical standards or type approval procedures.
5. Where the recovered petrol vapour is transferred to a storage tank, the vapour/petrol ratio shall be equal to or greater than 0.95 but less than or equal to 1.05.
6. Where an automatic monitoring system has been installed, the petrol vapour capture efficiency shall be tested and the results recorded at least once every three years by checking that the vapour/petrol ratio under simulated petrol flow conditions, or by any other appropriate methodology. Any such automatic monitoring system shall automatically detect faults in the proper functioning of the Stage II petrol vapour recovery system and in the automatic monitoring system itself, indicate faults to the operator and automatically stop the flow of petrol from any faulty dispenser if the fault is not rectified within seven days.
7. Where automatic monitoring systems have not been installed the in-service petrol vapour capture efficiency of the Stage II petrol vapour recovery systems shall be tested the results recorded at least once a year by checking that the vapour/petrol ratio under simulated petrol flow conditions, or by any other appropriate methodology.
8. Where automatic monitoring systems have not been installed a weekly functionality check shall be undertaken to verify the operation of the vapour recovery system.
9. A sign, sticker or other notification shall be displayed on, or in the vicinity of, the petrol dispenser, informing consumers that a Stage II petrol vapour recovery system is in use.

Incident Reporting

10. In the event of any incident at the site which could have an impact beyond the site boundary, the operator shall notify Council by telephone without delay on 01494 732058

Management

11. A copy of this permit shall be kept at the permitted installation. All staff that should be aware of its content shall be told where it is kept.

12. All relevant staff shall receive the necessary training and instruction to enable them to comply with the conditions of this permit.

13. The operator shall notify the Council of any changes to the persons nominated in the application as the primary point of contact, and deputy.

14. Maintenance and testing of vapour recovery systems shall be recorded.

15. All records made in compliance with this permit shall be kept in a written or computer log book or by using some other systematic method, and shall be clear and legible. If any entry is amended, a clear statement of the reason for doing so shall be included. Unless otherwise stated in this permit, all records required to be taken shall be kept available for inspection for at least **4 years** from the date of its being made. A copy of the manufacturer's instructions referred to in this permit shall be available for inspection on request.

Best available techniques

16. The best available techniques shall be used to prevent or, where that is not practicable, reduce emissions from the installation in relation to any aspect of the operation of the installation which is not regulated by any other condition of this permit.

Process changes

17. If the operator proposes to make a change in operation of the installation, he must, at least **14 days** before making the change, notify the regulator in writing. The notification must contain a description of the proposed change in operation. It is not necessary to make such a notification if an application to vary this permit has been made and the application contains a description of the proposed change. In this condition 'change in operation' means a change in the nature or functioning, or an extension, of the installation, which may have consequences for the environment.

Right to appeal

You have the right of appeal against this permit within 6 months of the date of the decision. The Council can tell you how to appeal [*or supply details with the permit*]. You will normally be expected to pay your own expenses during an appeal.

You will be liable for prosecution if you fail to comply with the conditions of this permit. If found guilty, the maximum penalty for each offence if prosecuted in a Magistrates Court is £50,000 and/or 6

Classification: OFFICIALClassification: OFFICIAL

Choose address from drop down

Tel: 01895 837200 | Fax: 01895 832750

www.chiltern.gov.uk | www.southbucks.gov.uk



CHILTERN
District Council



SOUTH BUCKS
District Council

Stronger in partnership

months imprisonment. In a Crown Court it is an unlimited fine and/or 5 years imprisonment. Our enforcement of your permit will be in accordance with the Regulators' Compliance Code

**Chiltern & South Bucks District Councils
Council Offices**

Strategic Environment Team

Healthy Communities Unit

King George V House

King George V Road

Amersham

HP6 5AW

(Address to where all correspondence regarding this permit should be sent)

Signed on behalf of Chiltern & South Bucks District Councils

A handwritten signature in black ink, appearing to read 'J. Conkley'.

Date: 6th June 2018

Senior Environmental Protection Officer

(An authorised officer of the Council and to whom any queries regarding the permit should be sent)

A handwritten signature in black ink, appearing to read 'J. Conkley'.

Date 6th June 2018

Environmental Health Manager

An authorised officer of the Council

Appendices

Appendix 1 – Site Plan/Map

Appendix 2 – Denotation of address

Appendix 3 – Tanking Layout info

Appendix 4 – Hand drawn forecourt sketch

Classification: OFFICIALClassification: OFFICIAL
Choose address from drop down
Tel: 01895 837200 | Fax: 01895 832750
www.chiltern.gov.uk | www.southbucks.gov.uk



Stronger in partnership

Appendix 1 – Site Plan/Map – H418/1/74/P1364/18/VAR/P1

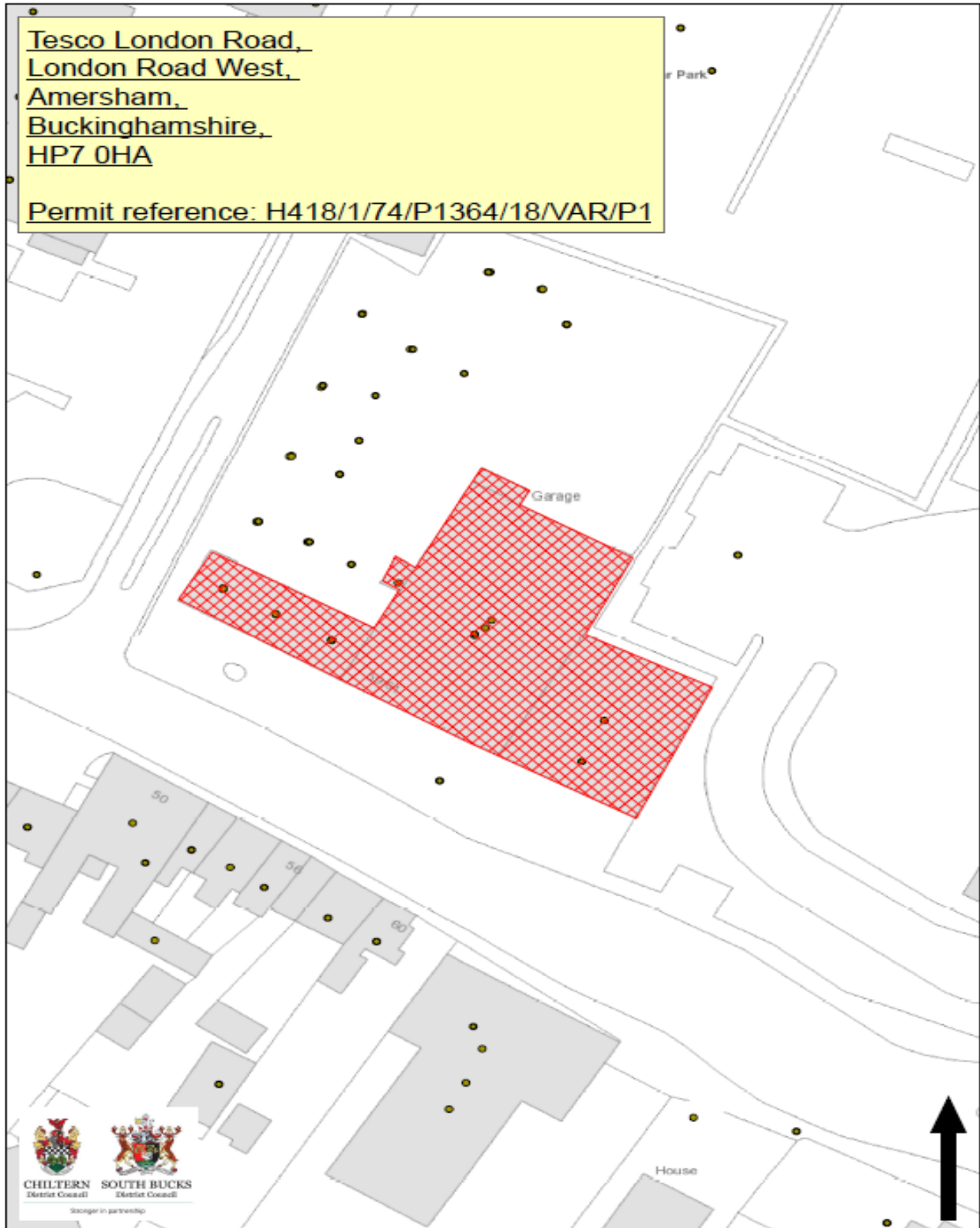

© Crown Copyright and database rights 2017. Ordnance Survey 100023578.

Classification: OFFICIAL Classification: OFFICIAL

Choose address from drop down

Tel: 01895 837200 | Fax: 01895 832750

www.chiltern.gov.uk | www.southbucks.gov.uk



CHILTERN
District Council



SOUTH BUCKS
District Council

Stronger in partnership

Appendix 2 - Denotation of Address – H418/1/74/P1364/18/VAR/P1



This map is reproduced from Ordnance Survey material with the permission of the Ordnance Survey on behalf of the Controller of Her Majesty's Stationery Office.
© Crown copyright. Unauthorised reproduction infringes Crown copyright and may lead to prosecution or civil proceedings. 100023578. 2009.

Appendix 3 – Tanking Layout Info

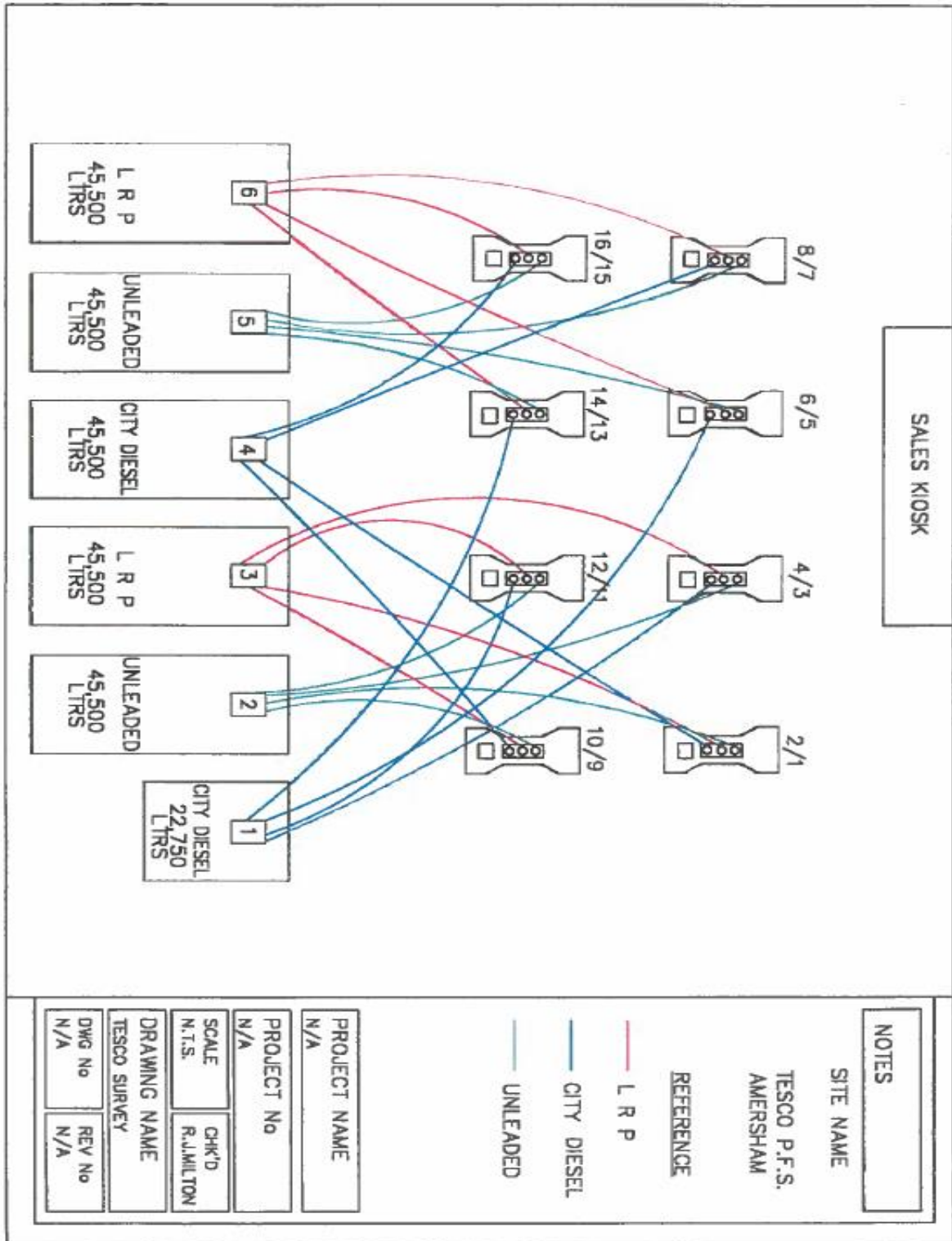

Appendix 4 – Forecourt sketch

